

APPROVED BY _____

DATE _____

PAINT CODE _____

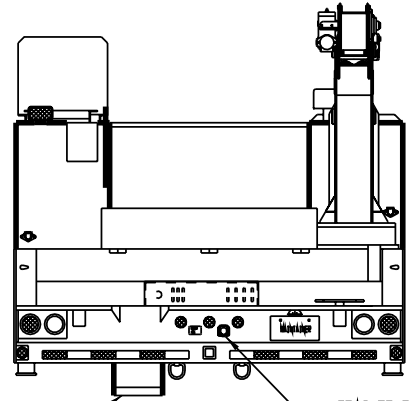
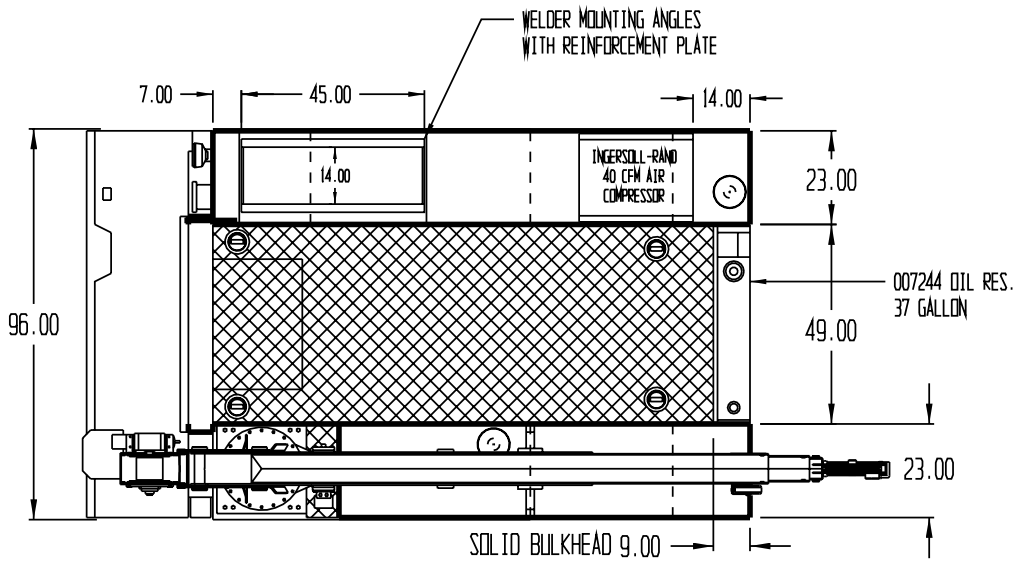
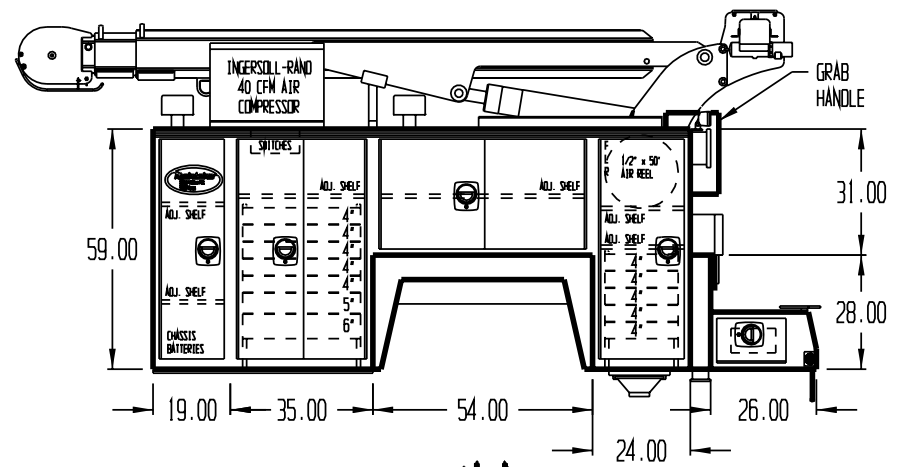
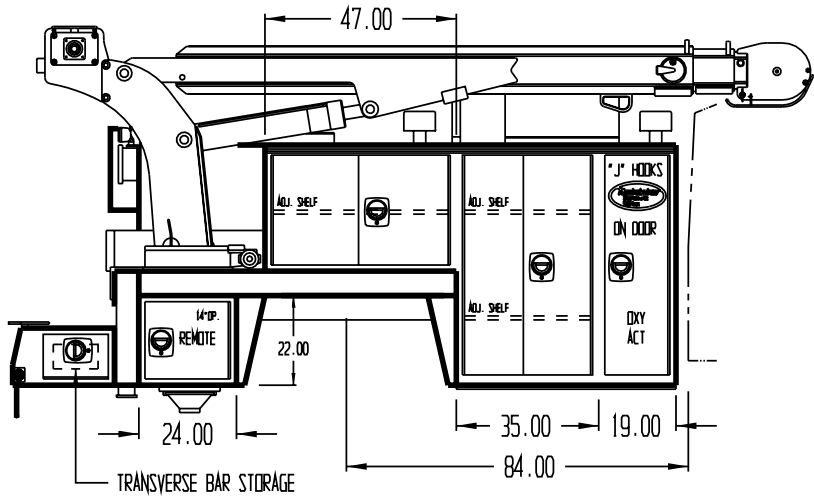

NOTE: (6) INTERIOR STRIP LIGHTED COMPARTMENTS
 (3) 36" SS 1, 2, & CS 2
 (6) 12" 2ea. SS 3, 4 & CS 3

NOTE: LINE-X CARGO CENTER DECK, COMPARTMENT TOPS, SIDES, & (NOT BACKS), FRONT BULKHEAD, TAIL GATE & TAIL GATE EXTENSION, REAR WORK BENCH BUMPER AND STEP

HYDRAULIC EXTEND IN/OUT OUTTRIGGER

NOTE: 20 GALLON AIR STORAGE IN CHASSIS FRAME

NOTE: USABLE CENTER DECK CARGO WIDTH 48.50"

NOTE: 8" SILLS & 4" X-MEMBERS

PLEASE REPORT ANY ERRORS FOUND ON THIS PRINT

THIS PRINT CONTAINS CONFIDENTIAL INFORMATION AND IS THE SOLE PROPERTY OF MAINTAINER CORP. OF IOWA INC. AND IS NOT TO BE COPIED OR REPRODUCED WITHOUT THE EXPRESSED WRITTEN PERMISSION OF MAINTAINER CORP. OF IOWA INC.

PROPRIETARY DATA PROPERTY OF MAINTAINER CORPORATION OF IOWA, INC.
COPYRIGHT © 2000
Maintainer
 Corporation of Iowa, Inc.
 P.O. Box 349 1701 S. 2nd Avenue
 Sheldon, Iowa 51201

MATERIAL:		SCALE: 1:32		SIZE: B	
DRAWING NUMBER: Z070K		DFTM. STZ		DATE: 12/10/07	
MADE IN THE USA		10000TT-2-084		STOCK / SIGNATURE-2	

LOS DIMENSIONS ARE IN INCHES
 GENERAL TOLERANCES
 BREAK ALL EDGES .01 X 45°
 ANGULAR ± 1°
 .XX ± .03
 .XXX ± .005
 LOS RADII
 LOS ANGLES