

NOTE: 4- TIE DOWNS IN CENTER DECK FLOOR  
4- TIE DOWNS IN CENTER DECK SIDE WALLS

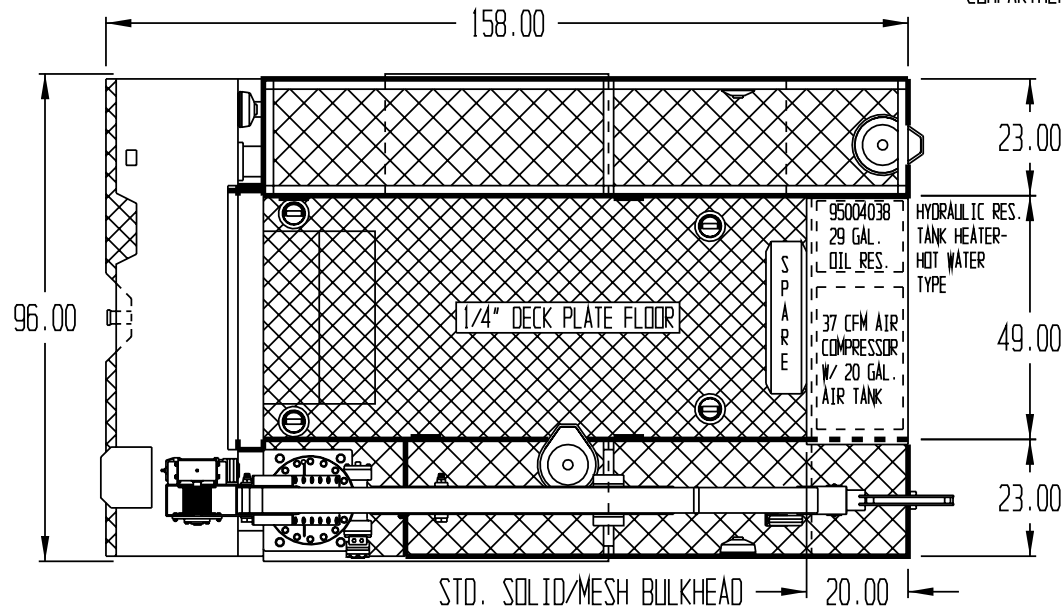

MASTER LOCK ON  
SS & CS REAR  
COMPARTMENTS

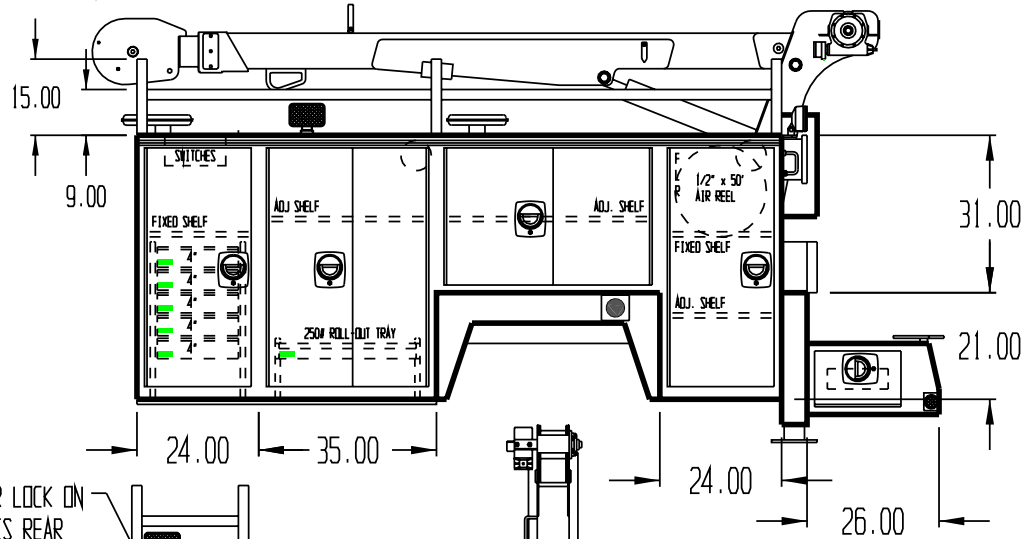
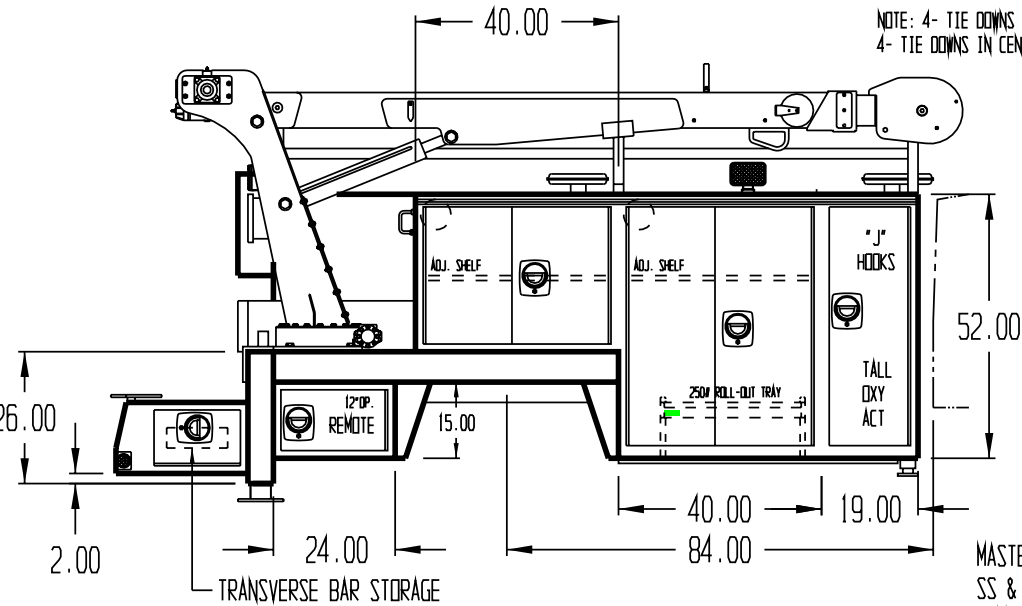
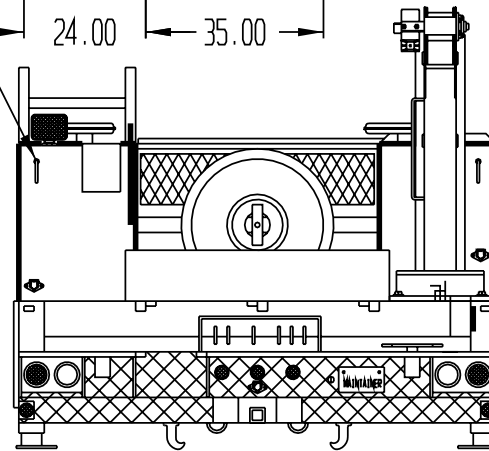

NOTE: 6-6" ROUND LIGHTS  
S.S. 1,2,3,4 & C.S. 2,3

NOTE: LINE-X CARGO CENTER DECK,  
COMPARTMENT TOPS, SIDES, & BACKS,  
FRONT BULKHEAD, TAIL GATE, &  
TAIL GATE EXTENSION, REAR WORK  
BENCH BUMPER, AND STEP

NOTE:  
USABLE CENTER DECK  
CARGO WIDTH 48.50"

PLEASE REPORT ANY ERRORS FOUND ON THIS PRINT

THIS PRINT CONTAINS CONFIDENTIAL INFORMATION AND IS THE SOLE PROPERTY OF MAINTAINER CORP. OF IOWA INC. AND IS NOT TO BE COPIED OR REPRODUCED WITHOUT THE EXPRESSED WRITTEN PERMISSION OF MAINTAINER CORP. OF IOWA INC.

PROPRIETARY DATA PROPERTY OF MAINTAINER CORPORATION OF IOWA, INC.  
COPYRIGHT © 2001

LDS DIMENSIONS ARE IN INCHES GENERAL TOLERANCES		MATERIAL:	
BREAK ALL EDGES .01 X 45°	ANGULAR ± 1° .XX ± .03 .XXX ± .005	SCALE: 1:26	SIZE: B
LDS RADI1	LDS ANGLES	DRAWING NUMBER: R336	DFTM. DJT

**Thaintainer**  
Corporation of Iowa, Inc.  
P.O. Box 349 1701 S. 2nd Avenue  
Sheldon, Iowa 51201  
DATE: 10-4-01

MADE IN THE  
USA

MTG-6-1-084