

LIFTMOORE 6036WX CRANE

36,000 FT.-LB. MOMENT RATING
6,000 LB. MAXIMUM CAPACITY

With a moment rating of 36,000 ft.-lbs. and a Maximum capacity of 6,000 lbs this crane offers plenty of capacity for field service jobs.

- 36,000 ft.-lbs. Moment Rating
- Designed for heavy lifting and precision spotting.
- Pistol grip pendant provides efficient one-person operation.
- Unlimited Rotation
- 12 V DC operating system

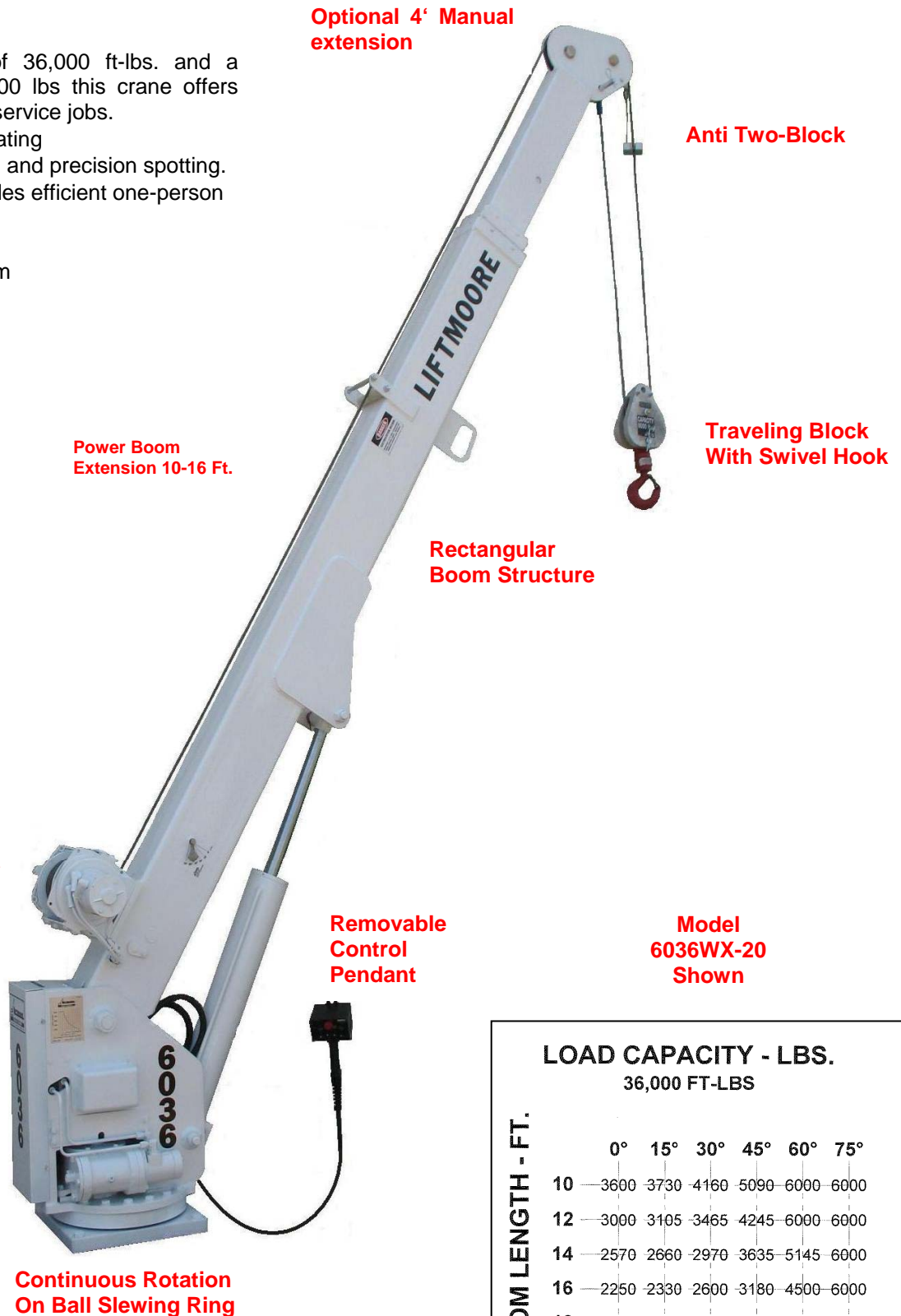

Optional 4' Manual extension

Anti Two-Block

Power Boom Extension 10-16 Ft.

Traveling Block With Swivel Hook

Rectangular Boom Structure

12 V.D.C
3 Stage Planetary Gear Winch

Removable Control Pendant

Model 6036WX-20 Shown

Worm Gear Rotation Drive

Continuous Rotation On Ball Slewing Ring

LOAD CAPACITY - LBS. 36,000 FT-LBS

BOOM LENGTH - FT.	LOAD CAPACITY - LBS.					
	0°	15°	30°	45°	60°	75°
10	3600	3730	4160	5090	6000	6000
12	3000	3105	3465	4245	6000	6000
14	2570	2660	2970	3635	5145	6000
16	2250	2330	2600	3180	4500	6000
18	2000	2070	2310	2830	4000	6000
20	1800	1865	2080	2545	3600	6000



HOUSTON, TEXAS
FAX: (800) 824-5559 (USA & Canada)
FAX: (713) 688-6324
PHONE: (713) 688-5533
www.liftmoore.com

713-688-5533
WWW.LIFTMOORE.COM

22380

6036WX SPECIFICATIONS

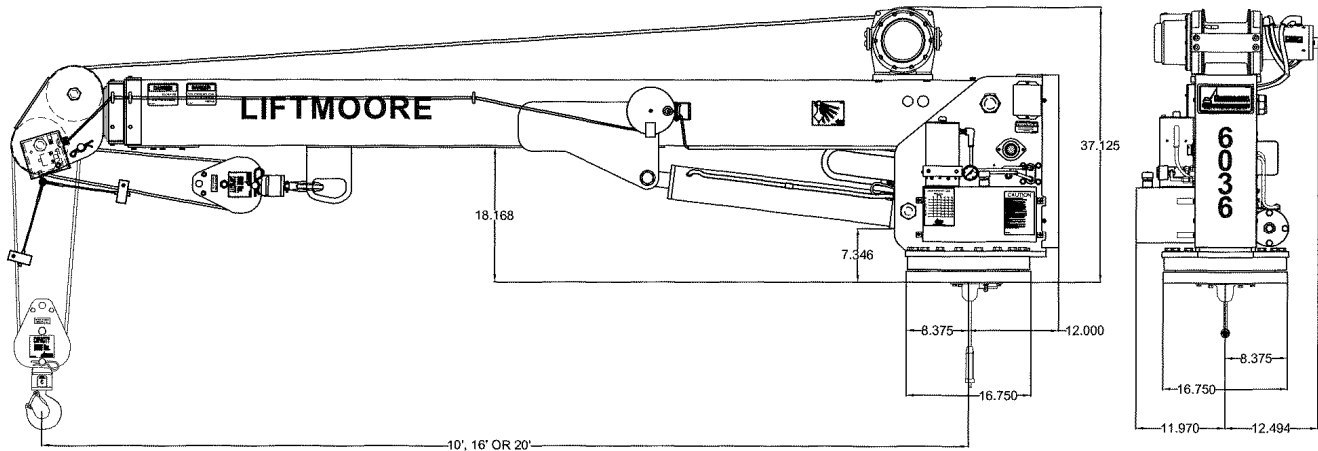

MOMENT RATING: 36,000 Ft.-Lbs.

LIFT CAPACITIES:

6000 lbs. @ 6 ft. *	2520 lbs. @ 14 ft.
4500 lbs. @ 8 ft. *	2250 lbs. @ 16 ft.
3600 lbs. @ 10 ft. *	2000 lbs. @ 18 ft.
3000 lbs. @ 12 ft.	1800 lbs. @ 20 ft.

* Double line required for loads above 3000 lbs.

HOIST WINCH: The hoist winch is a planetary gear driven for the most efficient operation in the industry. The winch is powered by a 2.5 HP 12-volt DC series wound electric motor. Single line no load speed of the winch is 28 feet per minute. Winch drum to wire line meets ANSI requirements.

WIRE ROPE and SHEAVES: The crane is supplied with 90 Ft. of 5/16 in. 6 X 36 wire rope. Cable breaking strength is 10,540 lbs. and conforms to ANSI requirements. The wire rope is outside of the boom and visible for operators continual inspection. A traveling block for easy two-part hookup is included. The block includes a roller thrust bearing swivel hook for easier rotation of the load. All sheaves meet ANSI requirements.

BOOM ELEVATION: The boom angle varies from -5 to +75 Degrees and powered by a 4.5 in. diameter double acting cylinder with an integral counterbalance valve. The counterbalance valve has three important functions. This valve holds the cylinder in the event of hose failure and it controls the rate of boom decent, and functions as a relief valve.

BOOM EXTENSION: The boom is extended hydraulically from 10 Ft. to 16 Ft. The hydraulic extension cylinder is mounted inside the boom for protection. A Counterbalance valve is mounted integral with the cylinder for safety. The power extendable portion slides on nylatron slide pads for minimum friction.

POWER SOURCE: This Crane operates on a 12 volt DC operating system. An additional battery is required and should be installed near the crane. This battery should be as large as possible. Use of a "Group 4D or larger" type battery is recommended. A master cutoff switch, quick disconnect, circuit breakers and 25 ft of battery wire for standard truck installation is provided.

ROTATION SYSTEM: The cranes rotation is powered through a worm gearbox for precise control and positive locking. The crane rotates on a gear bearing slewing ring. The electric swivel assembly allows continuous and unlimited rotation.

REMOTE PENDANT CONTROL: A 25-Ft. long remote pendant is provided for control of each powered function. All switches used in the pendant are momentary type. The Pendant control is removable from the crane to prevent unauthorized use of the crane. An E-Stop switch is provided to turn off power to the crane's functions in the event of an emergency.

LOAD SENSOR: A load-limiting sensor is supplied as standard. This sensor will shut down hoist up, boom out & boom down when an overload is detected. The sensor will reset after the load is lowered.

ANTI TWO-BLOCK: Anti two-block is standard on this crane & prevents extending the boom against the travel block and breaking the cable.

MOUNTING: Four 7/8" Grade 8 bolts are required. Bolts are not included. The crane mounts on a 16 3/4 in. square base plate with a 14 3/4 in. square bolt pattern.

OUTRIGGERS: An optional outrigger is needed for stability requirements of OSHA 1910.180. The outrigger is necessary to reduce the load on the crane's rotation mechanism and the truck's suspension.



HOUSTON, TEXAS
 FAX: (800) 824-5559 (USA & Canada)
 FAX: (713) 688-6324
 PHONE: (713) 688-5533
 www.liftmoore.com