

370 Air Adjusted Coupling

ORDERING INFORMATION

Coupling Only:

- 370

Standard Installation Kit:

- 370A: 370 Coupling, 502 Bolt Kit, 281 Air Chamber, 467 Air Chamber Adapter Bracket, 271 Thimble

Optional Accessories:

- Air Chamber 282 Type-30 (page 67): Provides a larger diaphragm for greater shoe force compared to 281 Air Chamber.
- Air Chamber Brackets (page 67): 467H (3/4 in. / 19 mm), 467F (5 1/2 in. / 140 mm)
- Thimbles (page 67): 271B (4 3/8 in. / 111 mm), 271C (5 1/2 in. / 140 mm)
- Drawbar Guides 378 (page 66): Helps guide drawbar eye into coupling.
- Wear Gage 14011 (page 66): To determine hook wear limits.
- Latch Gage 14026 (page 66): To determine latch gap limit.

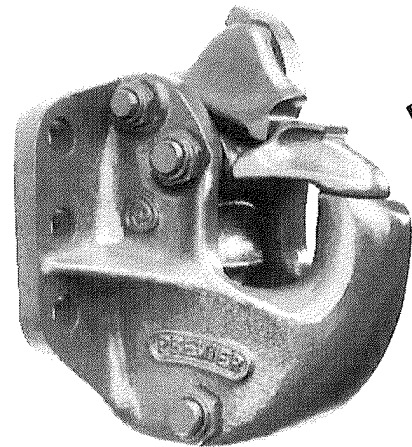

SPECIFICATIONS

Maximum Gross Trailer Weight:	90,000 lbs.	(40,823 kg)
Maximum Tongue Weight:	18,000 lbs.	(8,164 kg)
Ultimate Latch Capacity:	20,000 lbs.	(9,071 kg)
Maximum Eye X-Section:	1 13/16 in.	(46 mm)
Minimum Eye Opening:	2 3/8 in.	(60 mm)
Unit Weight:	30 lbs.	(13.6 kg)

Used frequently in dump and pup applications, our popular 370 offers users a low profile, high latch strength and our Premalloy body for maximum wear. This coupling must be used with an air service chamber.

STANDARD INSTALLATION DRAWING

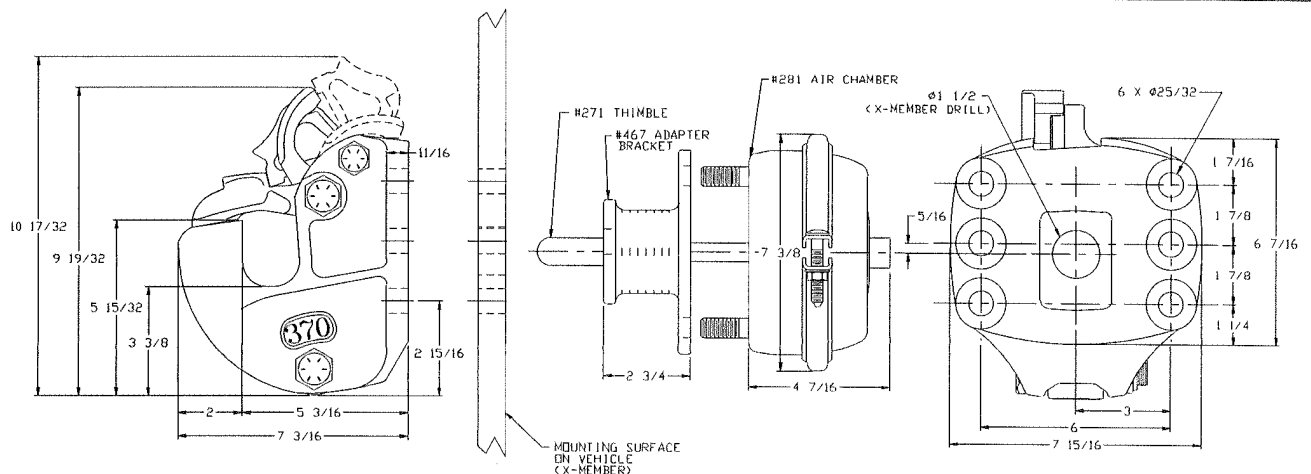

Pushrod length is 4 in. (102 mm) plus thickness of mounting structure for standard installations as illustrated.

REPLACEMENT PART INFORMATION

370PK Parts Kit Includes:

274A: Locknut	582A: Spring
372B: Locking Pawl	*266: Spring
373: Pawl	*271: Thimble
373A: Spring	*274: Bolt
373B: Spacer	*274A: Locknut
374: Bolt	*279: Shoe
375: Bolt	
375A: Locknut	
472: Latch	

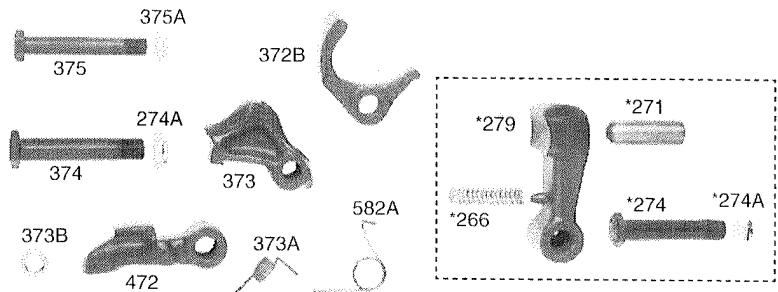

*Not included in parts kit, available individually.

IMPORTANT GUIDELINES that apply to all Premier Air Adjusted Couplings

- Do not weld on any coupling assembly
- Always use Grade-8 fasteners properly torqued
- Do not apply lubricants to the coupling hook
- Air service chamber must be Type-24 or Type-30 with 90-120 PSI air supply
- Clean & inspect coupling for damage & excessive wear prior to each and every use
- Lubricate all coupling components at a minimum of 90 day intervals
- Do not bind-up (Jackknife) any application as stresses can cause damage to products or components, resulting in failure and detachment of the trailer while in use

