

REVISIONS			
REV.	DESCRIPTION	DATE	APRVD

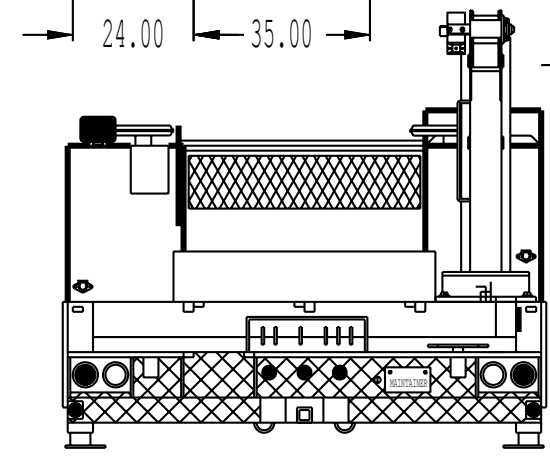
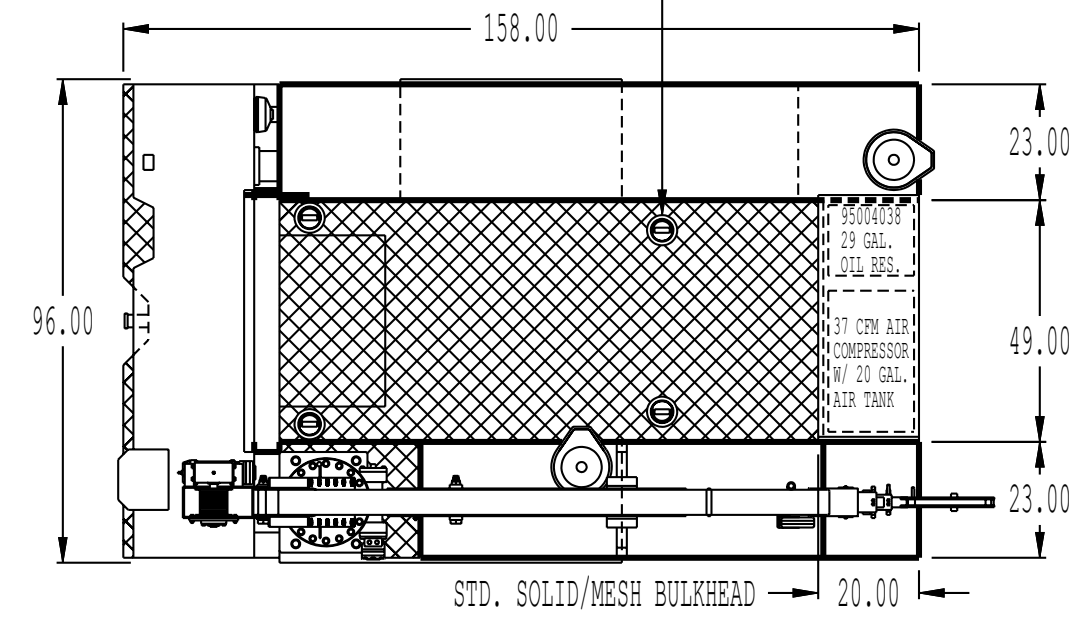
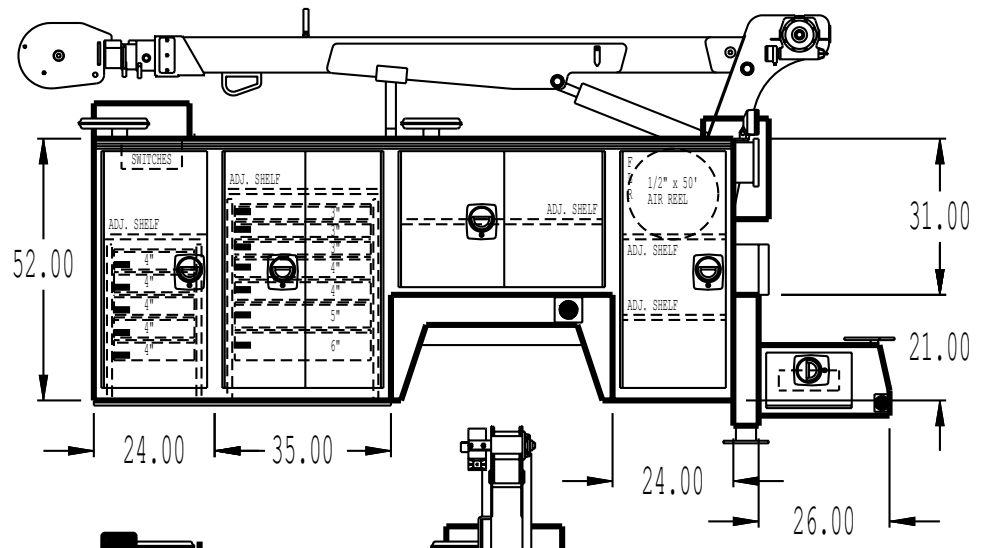
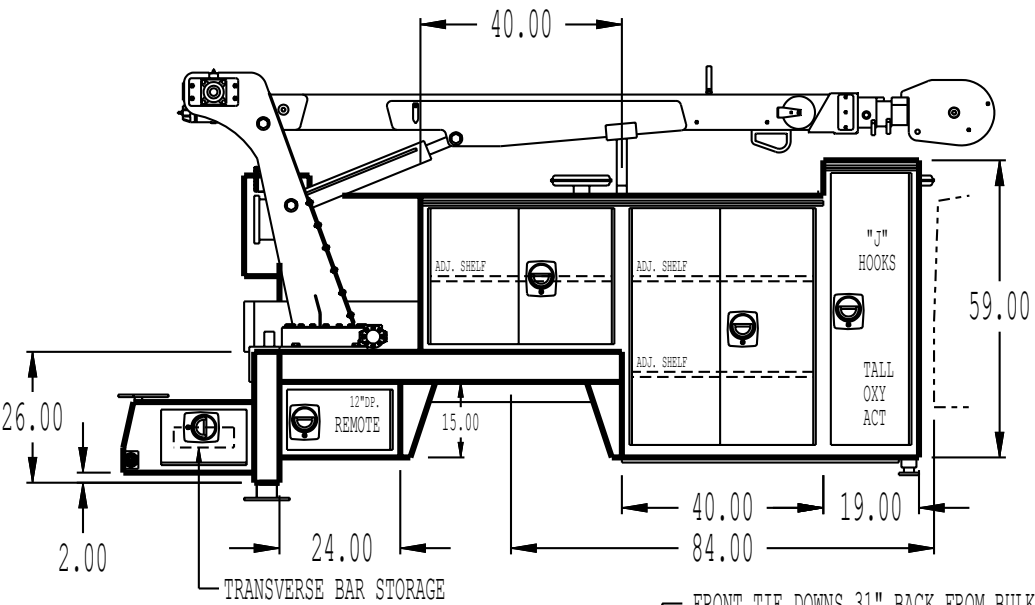

NOTE: INTERIOR STRIP LIGHTS
 (3) 36" SS 1, 2 & CS 2
 (6) 12" 2 EA. SS 3, 4 & CS 3

NOTE: LINE-X CARGO CENTER DECK,
 COMPARTMENT TOPS, SIDES, & BACKS,
 FRONT BULKHEAD, TAIL GATE, &
 TAIL GATE EXTENSION, REAR WORK
 BENCH BUMPER, AND STEP

NOTE:
 USABLE CENTER DECK
 CARGO WIDTH 48.50"

PLEASE REPORT ANY ERRORS FOUND ON THIS PRINT

THIS PRINT CONTAINS CONFIDENTIAL INFORMATION AND IS THE SOLE PROPERTY OF MAINTAINER CORP. OF IOWA INC. AND IS NOT TO BE COPIED OR REPRODUCED WITHOUT THE EXPRESSED WRITTEN PERMISSION OF MAINTAINER CORP. OF IOWA INC.		PROPRIETARY DATA PROPERTY OF MAINTAINER CORPORATION OF IOWA, INC.	
UOS DIMENSIONS ARE IN INCHES GENERAL TOLERANCES		MATERIAL:	
BREAK ALL EDGES .01 X 45°	ANGULAR ± 1° .XX ± .03 .XXX ± .005	SCALE: 1:26	SIZE: B
UOS RADII	UOS ANGLES	DRAWING NUMBER: S223	DFTM. KLJ DATE: 6-5-02
MADE IN THE USA		Thaintainer Corporation of Iowa, Inc. P.O. Box 349 1701 S. 2nd Avenue Sheldon, Iowa 51201	