



Keeps YOU on the go

Products:

- Service Bodies
- Lube Bodies
- Service/Lube Combos
- Lube Skids
- Cranes
- Accessories



www.maintainer.com

Maintainer's Quality Difference....



Crane base ties directly into body substructure

Inch by Inch The Best



Body substructure ties directly into chassis frame rails

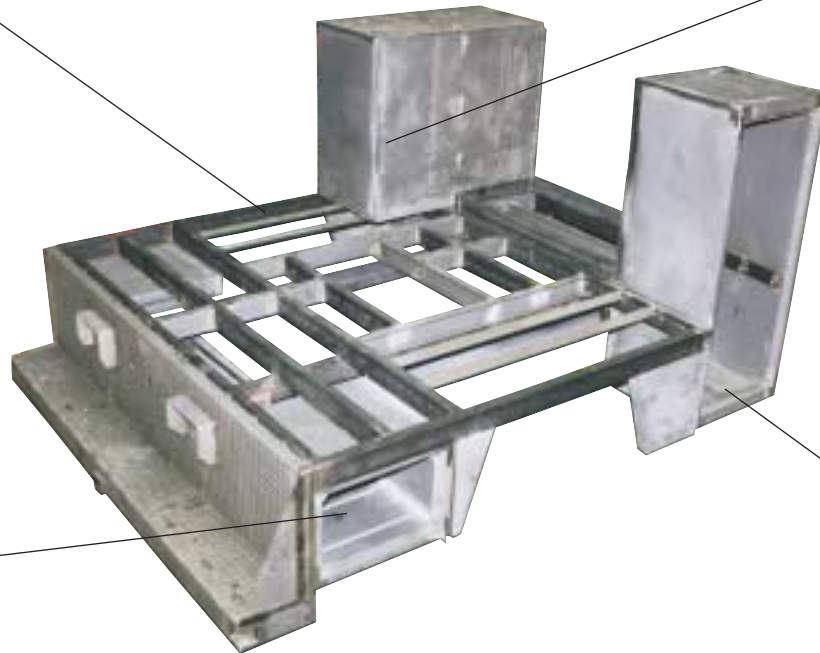
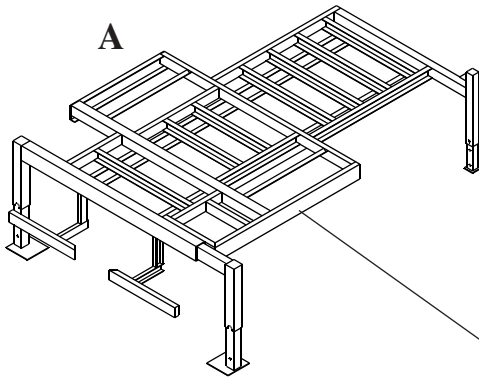

A. Full length main sills with overlapping cross members are on 12" centers.

B. Single piece 11 gauge doors include stainless steel hinges with 3 pt. door latches. Doors are recessed to eliminate water traps. Hold open hold closed gas shock door holders are standard equipment.

C. Maintainer outriggers have a clean design with no exposed hoses. Cylinders and cylinder rods are fully enclosed and protected in structural tubing.

D. Cabinets are fabricated from galvanized steel to resist corrosion. Radius door openings have automotive, metal backed, bulb type weather stripping. Compartment floors are ribbed for added strength. Compartments are 23" deep and available in 42, 52, and 59" high configurations.



Maintainer's Mission....



to manufacture and market the highest quality and highest value bodies for work trucks...

to exceed our customer's expectations by being responsive, efficient, and committed to continuous improvement of our products and our organization...



to understand that the customer determines when he is satisfied and it is his perception of value and quality that counts most...

to make our customers the focus of everything we do.





Galvanized Fixed or Adjustable
Shelves



Galvanized Heavy
to Fit

One and Two Ton Service Bodies

Maintainer Service Bodies are built to meet the most rugged on/off road conditions. Maintainer specializes in custom designed bodies that meet the highest quality standards.



MTSC1
(1-ton service body w/crane)



Duty Drawer Sets
Every Need



MTS1
(1-ton service body only)



MTSC1
(1-ton service body w/crane)



MTSC2
(2-ton service body w/crane)

For more information
on accessories see
Maintainer tab

Service Bodies



The Maintainer Difference... Keeps YOU on the go



Enclosed Hose Reel
Compartment



MTLS
(lube skid)

One and Two Ton Lube Bodies & Skids

Maintainer offers a wide range of heavy duty lube bodies and lube skids that meet the end user's exact needs. Both air and hydraulic product distribution systems are available.



MTL2
(2-ton lube body)



MTL1
(1-ton lube body)



MTL2
(2-ton lube body)



MTL2
(2-ton van style lube body)

For more information
on accessories see
Maintainer tab



Lube Bodies

The Maintainer Difference... Keeps YOU on the go

One & Two Ton Service/Lube Combos



MTSL1 (1-ton service/lube body)



MTSL2 (2-ton service/lube body)



Maintainer combination bodies are like two trucks in one. Whether it's mechanical repairs or lube service, Maintainer has the right combination for you.



E-Z Pick Electric
Crane



Short Tower Crane

Maintainer offers a wide range of hydraulic telescoping boom cranes, both short and tall tower configurations, from 3,500-lbs. to 14,000-lbs. capacity... plus a 12-volt model 657 E-Z Pick 2000-lb. electric crane.



Tall Tower Crane

For more information
on accessories see
Maintainer tab



The Maintainer Difference... Keeps YOU on the go

Combos and Cranes

Accessories & Options...



Small Parts Bins



Tall Oxy/Act
Compartment

Tough Line-X
Protective
Coating
Applied to
Bumper and
Cargo Area.



Work Bench Bumper with Vise Mount
and Side Compartments



Heavy Duty 250-lb.
Capacity Roll-Out Drawers

When it comes to field service, Maintainer has a body that will get the job done quickly and efficiently for you. Maintainer features a wide variety of options to meet your exact needs.



Spacious cargo area and workbench bumper; roll-out used filter storage bin, and a welder cut-out compartment are just a few of the options Maintainer has to offer.

Hydraulic Driven Air Compressor

Evac System

Adjustable Shelves

Welder

Spare Tire Rack

Flood Lights

Heavy Duty Toolbox Riser

Grab Handles

Roll Out Drawers



Maintainer



The Maintainer Difference... Keeps YOU on the go

Maintainer

Difference...

"We at Russell & Sons Construction Company appreciate the professional sales, service, and product Maintainer has provided us."

Larry L. Russell,
Russell & Sons Construction



★ **Sheldon**

"I feel that as we continue to update our fleet, Maintainer will be our preferred vendor because of their dedicated people and willingness to support their premium product."

Joe Chandler & Butch Ballard,
J.A. Riggs Tractor Co.

"Maintainer bodies are designed with the mechanic or technician in mind. They definitely provide a quality product."

Steve Sims, Senior Manager-
Fleet Vehicles,
Burlington Northern Santa Fe

"The truck rolled in this morning about 7:00. It looks great. We will spend the day studying all of the systems and give her a thorough shake down. We will then move in and go to work. I am very impressed with the workmanship and attention to detail."

Donald J. Hays,
Hays Utility Service

"We certainly appreciate the structural soundness and integrity of your truck bodies over other brands we are using. There is no question your quality is exceptional."

D. Michael Schumm, Elsinore Valley
Municipal Water District

"Maintainer was the most diligent of the companies responding to our bid and the only one willing to build a service truck the way we wanted it!"

Larry Baggett,
City of Colorado Springs

Maintainer

Corporation of Iowa, Inc.

P.O. Box 349 Sheldon, IA 51201
Tel: 712-324-5001 Fax: 712-324-3526
Toll free: 800-831-8588
Web Address: www.maintainer.com

Distributed By:

